

PUMPER BODY

Medium Aluminum 2nd Gen Pumper

CHASSIS

Impel Chassis

CHASSIS AXLE, FRONT, CUSTOM

19,500 Lb Meritor Axle

AXLE, REAR

27,000 Lb Meritor Axle

ENGINE

370 HP Cummins L9 Engine

TRANSMISSION

Allison 5th Gen, 3000 EVS P

BUMPER

19" Extended Stainless Steel

CAB

6010 Impel FR Cab

BODY WATER TANK

750 Gallon Poly Water Tank

COMPT, PUMPER, REAR

51.25" FF RollUp Rear Compt

COMPT, PUMPER, LEFT SIDE

152" RollUp Full Height Front & Rear FDLR

COMPT, PUMPER, RIGHT SIDE

152" RollUp Full Height Front & Rear FDLR

FIRE SUPPRESSION PUMPHOUSE

52" Control Zone Top Mount

PUMP

1500 GPM Waterous CSU

CROSSLAYS, 1.50"

1.50" Crosslays Not Required

CROSSLAYS, 2.50"

(1) 2.50" Standard Capacity

SPEEDLAYS

(2) 1.50" Std. Capacity

GENERATOR

Generator Not Required

Foam System

Husky 12 Single Agent Foam System

Foam Cell

30 Gallon Foam Cell, Not Reduced Water

114.00 (9'-6") APPROX O.A.H.

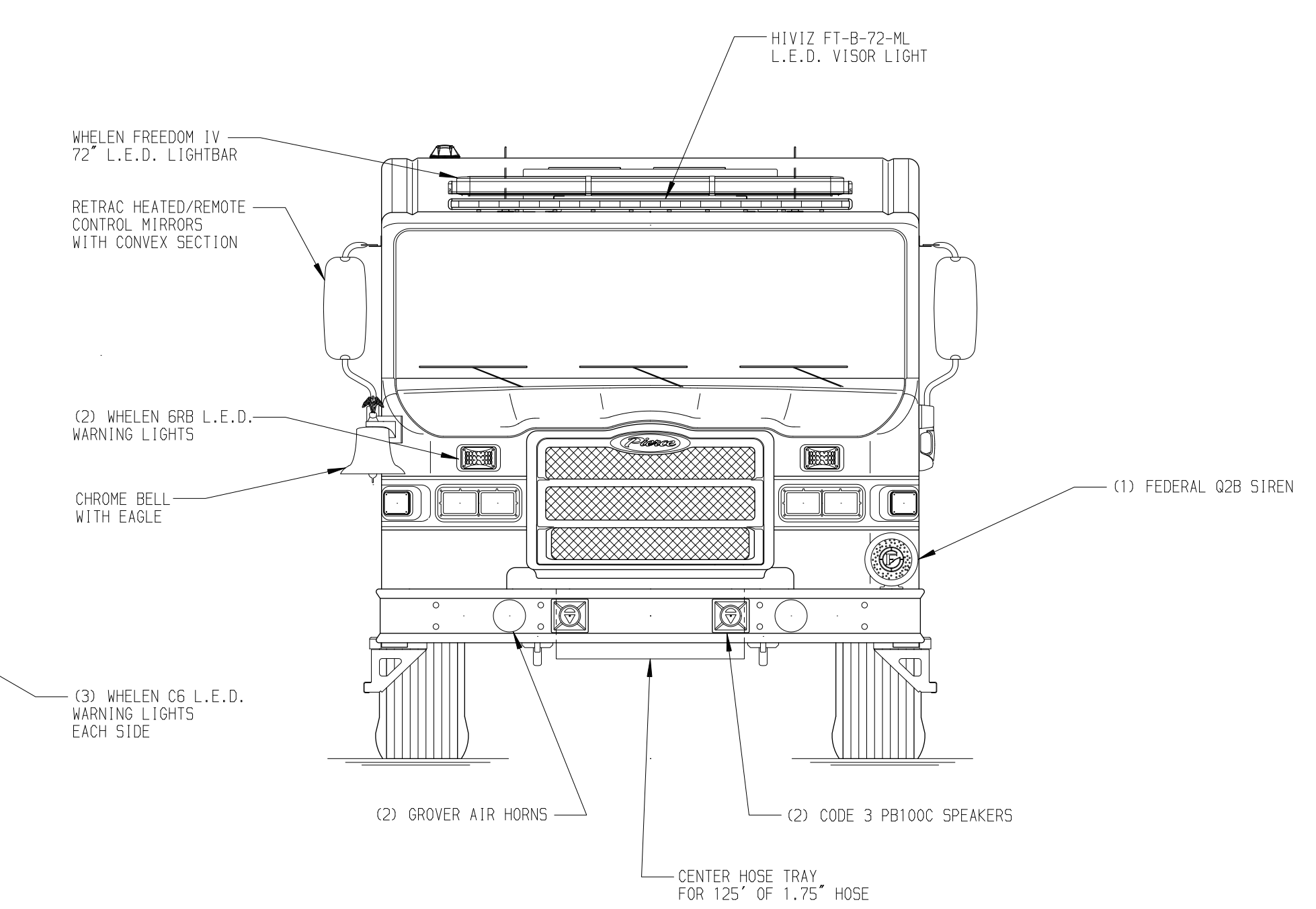
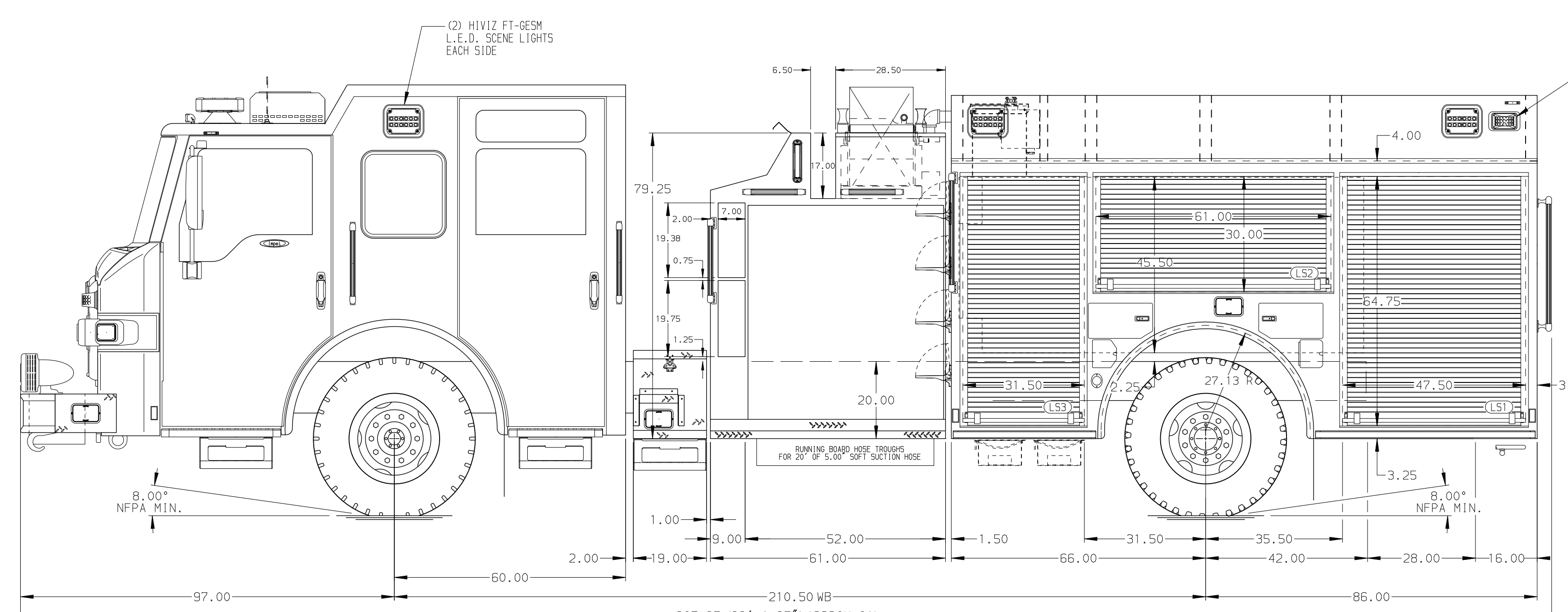
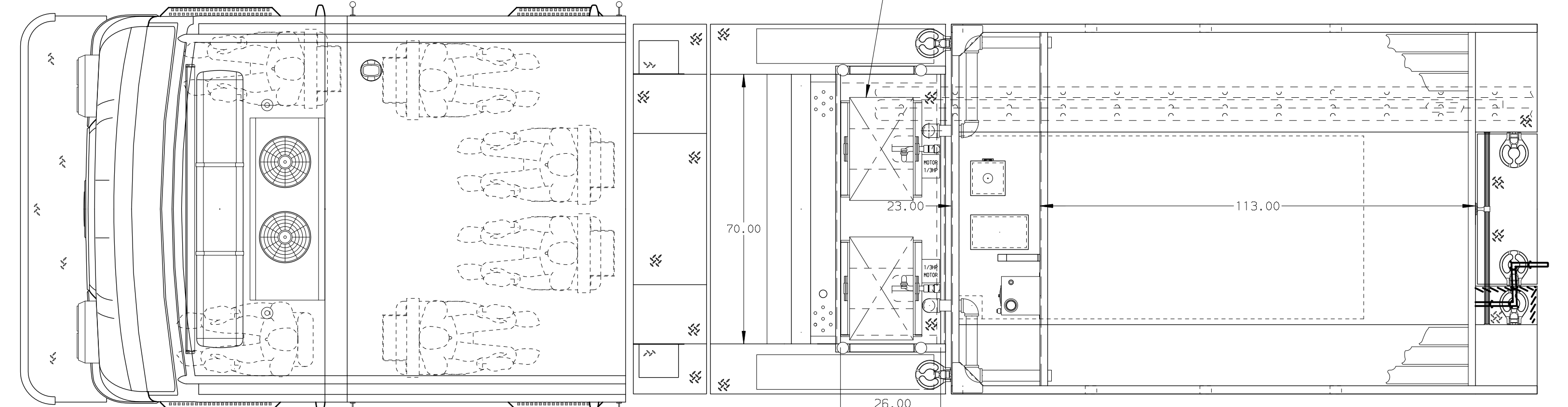
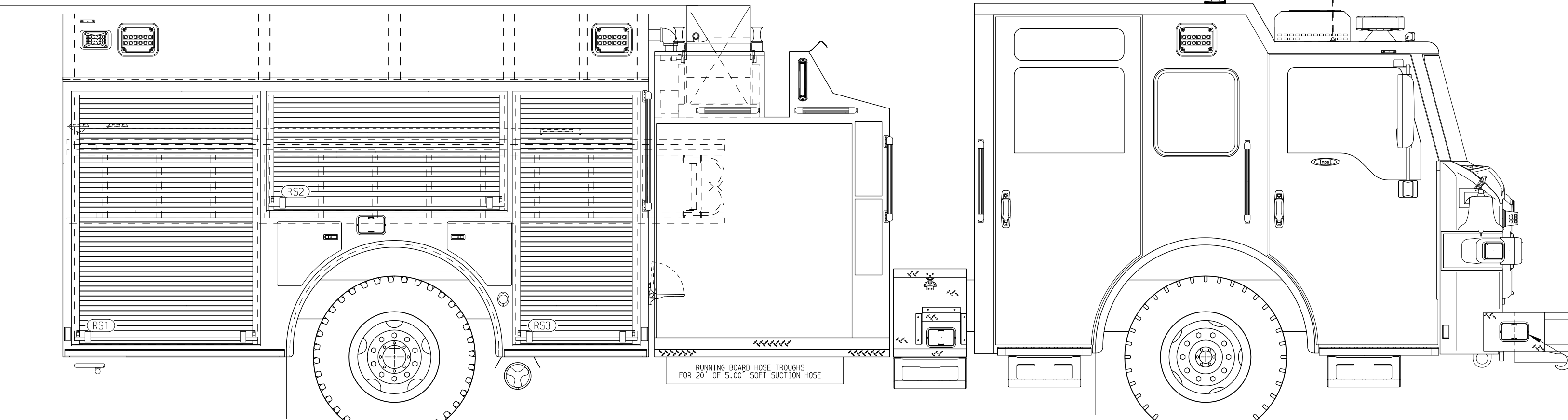

HOSEBED CAPACITY	
BED 1	250' OF 2.50" D.J. POLY HOSE
BED 2	1200' OF 5.00" D.J. POLY HOSE
BED 3	500' OF 2.50" D.J. POLY HOSE
BED 4	250' OF 2.50" D.J. POLY HOSE

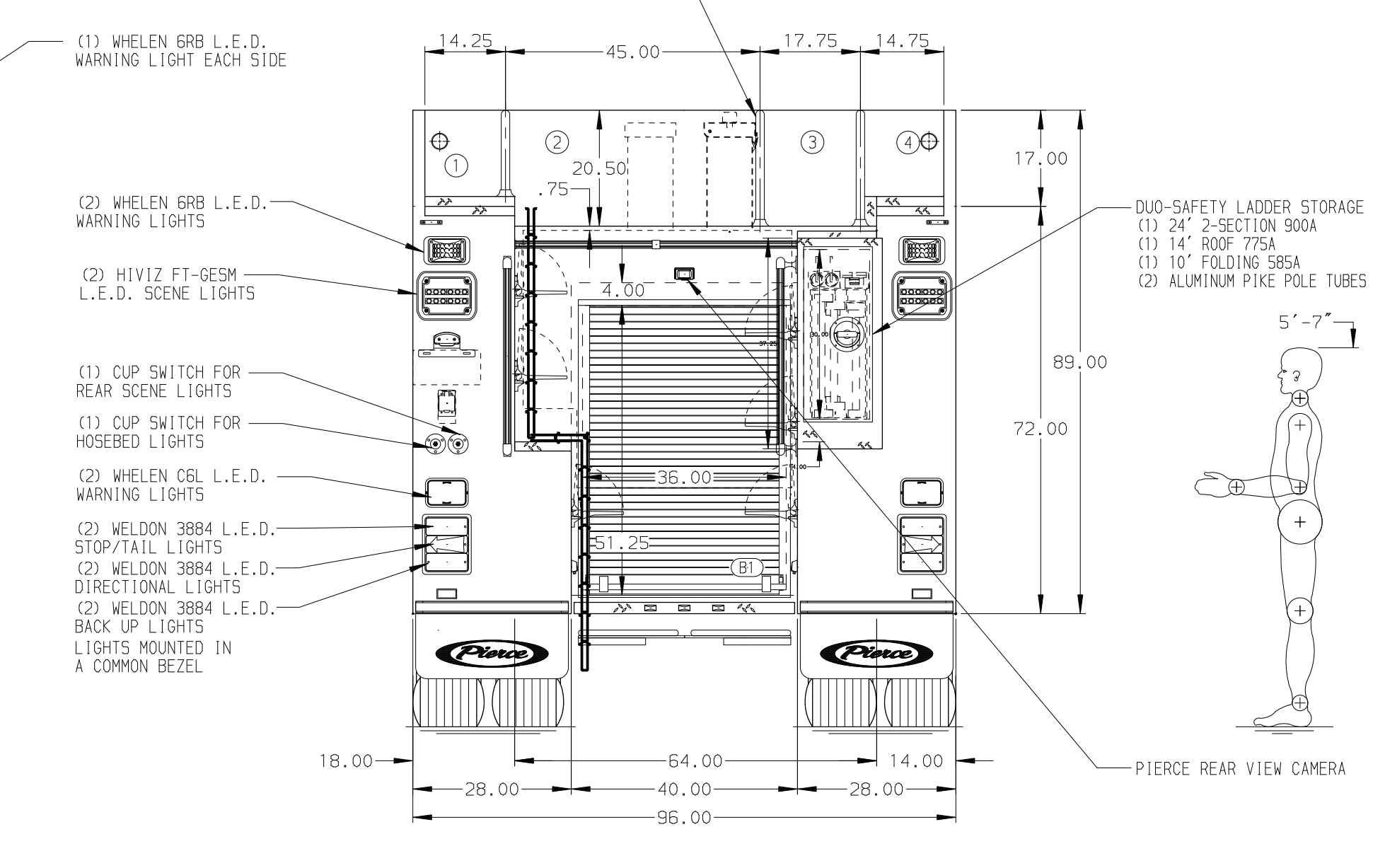

MAXIMUM O.A.H. 119.00"

NOTE
DIMENSIONS SHOWN ARE APPROXIMATE AND ARE SUBJECT TO MINOR DEVIATIONS AS MAY OCCUR OR BE NECESSARY IN CONSTRUCTION. MINOR DETAILS NOT SHOWN.

- ONE 1.50" OUTLET WITH 2.00" PIPING AND SWIVEL LOCATED IN CENTER BUMPER TRAY
- SHORELINE RECEPTACLE WITH KUSSMAUL SUPER AUTO-EJECT LOCATED ON DS PUMP PANEL, PS PUMP PANEL AND DS REAR BULKHEAD
- AIR INLET WITH DISCONNECT COUPLING IN THE DRIVER SIDE STEERWELL
- BATTERY CHARGER LOCATED IN COMPARTMENT PER SHOP ORDER
- BATTERY CHARGE INDICATOR LOCATED NEAR DRIVER SEAT RISER WITH BRACKET
- SIX ADJUSTABLE SHELVES IN COMPARTMENTS PER SHOP ORDER
- ONE FLOOR MOUNTED SLIDE-OUT TRAY IN COMPARTMENT PER SHOP ORDER
- ONE SWING-OUT TOOLBOARD LOCATED IN COMPARTMENT PER SHOP ORDER
- CTECH TWO DRAWER ASSEMBLY LOCATED IN COMPARTMENT PER SHOP ORDER
- SIX PEGBOARDS MOUNTED ON BACK WALL IN COMPARTMENTS PER SHOP ORDER

- FOUR AIR BOTTLE STORAGE BINS LOCATED PER SHOP ORDER

REV	DATE	BY	CH	IMPEL FR
13JUL21	MMF	CSH	MAKE	CHASSIS DATA
18MAY21	COL	CSH	PIERCE	FOR
23MAR21	MMF	COL	MODEL	DWG NO.

Pierce MANUFACTURING INC.		JOB NO.	36008
		SCALE	DATE
		1:24	
		DRAWN BY	19MAR21
		MMF	
		CHECKED BY	22MAR21
		COL	
		SHEET SIZE	SHEET NO.
		D	1 OF 1

Pierce Pumper Approval Drawing
Cleveland Fire Department
36008AD